

PRODUCT SPECIFICATION

A

A

1. PRODUCT: TOUCH PANEL

2. PART NUMBER: T010-1301-T260

3. ATTACHED DRAWING: Tech Bes TTI-04007

TOUCH PANEL SPECIFICATION DOCUMENT No.

B

B

SIGNATURE FOR YOUR RECEIPT
-----
DATE:

C

C

TRANSTOUCH TECHNOLOGY INC. (TTI)  
DOCUMENT No.: TTI PRODUCT TECHNOLOGY Dept.

D

D

MANAGER: \_\_\_\_\_ DATE: \_\_\_\_\_

TTI PRODUCT TECHNOLOGY Dept.  
3F No.50 Hwa-Ya 3<sup>rd</sup> Road,Kwei-san Shian Tao-yuan ,Taiwan  
TEL:(03)3978800 FAX:(03)3978855

DOCUMENT CONTROL SECTION  
DATE

PROPRIETARY NOTE

This document contains information confidential and proprietary to TRANSTOUCH TECHNOLOGY INC. (TTI) and shall not be reproduced or transferred to other documents or disclosed to other or used for any purpose other than for witch it was obtained without the expressed written consent of TRANSTOUCH TECHNOLOGY INC. (TTI)

E

						TITLE: TOUCH PANEL SPEC.	
						DRAW NO. Tech Bes - 04007	
						CUST	
EDIT	DATA	DESIG	CHECK	DESCRIPTION		富晶通科技股份有限公司	
DESIGN	20040427	郭信杰	CHECK		APPR	TRANSTOUCH TECHNOLOGY INC	SHEET 1/12

F

1

2

3

4

A

A

B

B

C

C

D

D

E

F

觸控面板製品規格書  
TOUCH PANEL SPECIFICATION

富晶通科技股份有限公司  
TRANSTOUCH TECHNOLOGY INC

www.szlongsun.net

DATE	DOCUMENT CONTROL SECTION
------	--------------------------

					TITLE: TOUCH PANEL SPEC.	
					DRAW NO. Tech Bes - 04007	CUST
EDIT	DATA	DESIG	CHECK	DESCRIPTION		富晶通科技股份有限公司
DESIGN	20040427	郭信杰	CHECK		APPR	TRANSTOUCH TECHNOLOGY INC
						SHEET 2/12

觸控面板製品規格書  
TOUCH PANEL SPECIFICATION

1. 適用範圍 Application

此規格書是適用富晶通科技股份有限公司所製作的觸控面板。  
This specification is applied to TOUCH PANEL made by  
TRANSTOUCH TECHNOLOGY INC. (TTI)。

【製品圖號 手配圖號 Product No.】

品名 Name	製品圖號 P/No.	備註 Remark
觸控面板 TOUCH PANEL	T010-1301-T260	指輸入 7 inch For finger input

2. 概要 Function

此製品是裝置在 LCD 等平面顯示器上使用電阻薄膜的觸控面板。以先端有小 R 的筆或是以手指按下觸控面板的表面，觸控面板的電壓會透過檢出迴路將座標值檢測出來。  
TTI TOUCH PANEL is resistance type that customer uses with flat display like LCD. Once operator touches it by resin PEN with round end or FINGER, The circuit for TOUCH PANEL sends coordinate point to PC from voltage at contact point.

3. 製造者 MANUFACTURER

富晶通科技股份有限公司 TRANSTOUCH TECHNOLOGY INC. (TTI)  
所在地:桃園縣龜山鄉(華亞科技園區)華亞三路 50 號 3 樓  
Address: 3F No.50 Hwa-Ya 3<sup>rd</sup> Road ,Kwei-san Shian Tao-yuan ,Taiwan

4. 外型 OUTSIDE

4.1 外型圖 DRAWING

參考最後附加圖面

Please refer the last page of this spec.

DOCUMENT CONTROL SECTION  
↑  
DATE

						TITLE: TOUCH PANEL SPEC.	
						DRAW NO. Tech Bes - 04007	
						CUST	
EDIT	DATA	DESIG	CHECK	DESCRIPTION		富晶通科技股份有限公司	
DESIGN	20040427	郭信杰	CHECK		APPR	TRANSTOUCH TECHNOLOGY INC	SHEET 3/12

A

4.2 用語定義 Defines of words

用語 Words	定義 Defines
動作保證範圍 Guaranteed active area	觸控面板的特性保證範圍。 Area to be guaranteed all characteristics stated on this spec.
上蓋邊界 Boundary line of top enclosure	表示上蓋外框的建議位置。 Recommended boundary line of top enclosure
透明範圍 View (transparent) area	雙面膠或是從電極內側的透明範圍。 View area which is inside adhesive zone or electrode pattern. Top enclosure must not be fixed bye this area.

B

5. 特性 Characteristics

5.1 光學特性 Optical characteristics

	項目 ITEM	規格 SPECIFICATION	備註 REMARKS
1	全光線透過率 TRANSPARENCY	82% TYP. (動作保證範圍內) (Inside of guaranteed active area. )	JIS K-7105
2	HAZE	8.0% TYP.	

C

5.2 環境特性 Environmental characteristics

	項目 ITEM	規格 SPECIFICATION	備註 REMARKS
1	動作溫度 Operation temperature	-20°C ~70°C	最大露点温度 38 Max.wetTemp.is38°C (結露不許) (No dew)
2	保存溫度 Storage temperature	-30°C ~85°C	
3	動作濕度 Operation Humid.	20~90% RH	
4	保存濕度 Storage temperature	10~90% RH	

D

DOCUMENT CONTROL SECTION  
↑  
DATE

						TITLE: TOUCH PANEL SPEC.	
						DRAW NO. Tech Bes - 04007	
						CUST	
EDIT	DATA	DESIG	CHECK	DESCRIPTION		富晶通科技股份有限公司	
DESIGN	20040427	郭信杰	CHECK		APPR	TRANSTOUCH TECHNOLOGY INC	SHEET 4/12

F

5.3 機械特性 Mechanical characteristics

項目 ITEM	規格 SPECIFICATION	備註 REMARKS
1 表面硬度 Hardness of surface	鉛筆硬度 3H 以上 Pencil hardness 3H min.	JIS K-5400
2 FPC 剝離強度 FPC peeling strength	5N 以上 5N Min	向上垂直剝離 Peeling upward by 90°
3 入力荷重 Operation force	指 Finger  Max : 50gf	動作保證範圍內(不包含 Dot 上方) Within" guaranteed active area" (Not include above the Dot)

5.4 電氣特性 Electrical characteristics

項目 ITEM	規格 SPECIFICATION	備註 REMARKS
1 額定電壓 Rated Voltage	DC 7V max.	
2 電極間電阻 Resistance	X axis : 270Ω ~ 1200Ω (FILM 側) Y axis : 130Ω ~ 700Ω (GLASS 側)	FPC 連接端測量 At connector
3 直線性 Linearity	MAX : 1.5% 「最初值」 「initial value」 MAX : 3.0% 「環境及壽命試驗後」 「after environmental & life test」	測定條件請參照註 1 Refer Note-1
4 CHATTERING	10ms 以下 max At connector pin	5Hz 測定方式同 6.1 項 Condition: same as 6.1 as stated
5 絕緣電阻 Insulation Resistance	10MΩ 以上 (DC 25V) 10MΩ min (DC 25V)	

DOCUMENT CONTROL SECTION

DATE

↑

				TITLE: TOUCH PANEL SPEC.	
				DRAW NO. Tech Bes - 04007	
				CUST	
EDIT	DATA	DESIG	CHECK	DESCRIPTION	
DESIGN	20040427	郭信杰	CHECK	APPR	富晶通科技股份有限公司 TRANSTOUCH TECHNOLOGY INC
					SHEET 5/12

註 1: Note-1

直線性測定條件

Measurement condition of Linearity

在動作保證範圍內，沿著 X、Y 各軸的直線上任意複數點將最外端的點連結成一假想直線，相對於此線的偏差值。直線性是基準電壓分割值得最大偏差電壓。

Difference between actual voltage & theoretical voltage is an error at any points. Linearity is the value max.

Error voltage divided by voltage difference on active area.

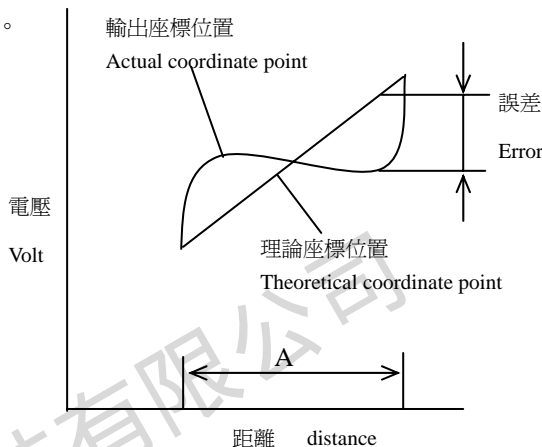

A: 動作保證範圍  
Guaranteed active area

6. 耐久性 life test condition

6.1 機械特性 Mechanical characteristics

1	打點壽命 Input life	100 萬回以上 10 <sup>6</sup> times min	動作保證範圍內 Within "guaranteed active area"
---	--------------------	---------------------------------------	--------------------------------------------

※ 入力荷重測定條件

Measurement condition of operation force

按下 film 表面，X 軸 Y 軸間的電阻值在 2kΩ 以下時所測得的入力荷重。

Resistance between X & Y axis must be equal or lower than 2kΩ (R<sub>on</sub> ≤ 2kΩ)。

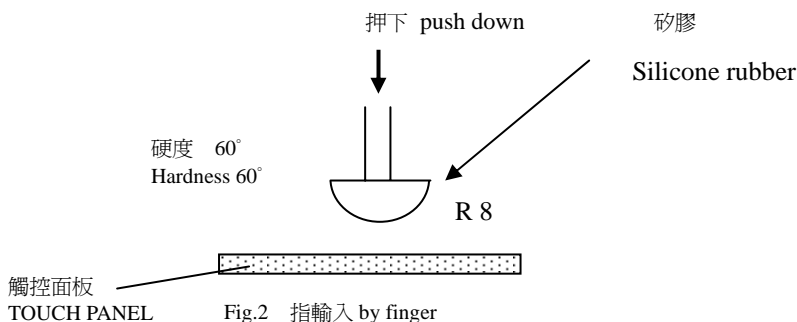

DOCUMENT CONTROL SECTION  
DATE

						TITLE: TOUCH PANEL SPEC.	
						DRAW NO. Tech Bes - 04007	
						CUST	
EDIT	DATA	DESIG	CHECK	DESCRIPTION		富晶通科技股份有限公司	
DESIGN	20040427	郭信杰	CHECK		APPR	TRANSTOUCH TECHNOLOGY INC	SHEET 6/12

※打點壽命(耐久性) 試驗條件

Input life test condition( by finger )

使用矽膠在同一地方連續打點  
Tapping same point by silicone rubber.

- 橡膠尖端 Shape of rubber tip : R8 硬度 Hardness 60°(Refer fig.2)
- 操作力 Load : 200g
- 操作頻率 frequency : 5Hz

【 判定基準 judge base 】

關於入力荷重、絕緣電阻、電極間電阻需滿足 5.3 , 5.4 的特性  
Operation force, Insulation resistance & Resistance stated before as 5.3 & 5.4 must be within spec.

6.2 環境測試條件 Environmental test condition

	項目 ITEM	規格 SPECIFICATION	備註 REMARKS
1	高温試驗 High temperature	85°C , 240 hr (Keep normal condition 2hr after test)	關於入力荷重、絕緣電阻、電極間電阻需滿足 5.3 , 5.4 的特性 Operation force, Insulation resistance & Resistance stated before as 5.3, 5.4 must be within spec.
2	低温試驗 Low temperature	-30°C , 240 hr (Keep normal condition 2hr after test)	
3	高濕動作試驗 Humidity operation	50°C , 95% RH, DC 5V , 36hr (Keep normal condition 24hr after test)	
4	熱衝擊試驗 Thermal shock	- 20°C ~ +70 (0.5hr each) 50 cy (Keep normal condition 2hr after test)	

DOCUMENT CONTROL SECTION  
DATE

					TITLE: TOUCH PANEL SPEC.	
					DRAW NO. Tech Bes - 04007	
					CUST	
EDIT	DATA	DESIG	CHECK	DESCRIPTION		
DESIGN	20040427	郭信杰	CHECK	APPR	富晶通科技股份有限公司 TRANSTOUCH TECHNOLOGY INC	
					SHEET	7/12

7 · 外觀規格 Appearance.

7.1 外觀基準適用領域(範圍) Scope of reject criteria.

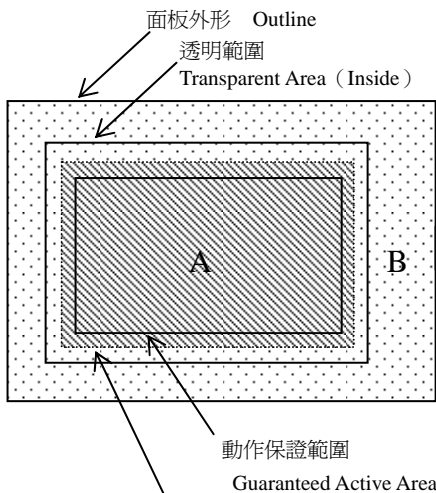

領域 Area	外觀仕様 Spec.
A	使用上不會有可視的缺失而影響正常操作。檢查基準依據 7-2 項。 Without any defect point to effect on normal operation.
B	不檢查 None-specify.

A : 誤入力防止區境界(波浪狀)的內側區域  
Inside of Boundary Line of Anti-input area.  
(Wavy-pattern)

B : 領域 A 以外  
Without A area. Input area refers to drawing as left.

DOCUMENT CONTROL SECTION	↑
DATE	

						TITLE: TOUCH PANEL SPEC.	
						DRAW NO. Tech Bes - 04007	
						CUST	
EDIT	DATA	DESIG	CHECK	DESCRIPTION			
DESIGN	20040427	郭信杰	CHECK		APPR		
						富晶通科技股份有限公司 TRANSTOUCH TECHNOLOGY INC	
						SHEET 8/12	



7.2 檢查基準 Reject criteria.

項 目 Description		檢查基準 Reject criteria	
FILM 打痕(魚眼) Film fish eye	Area	$0.1\text{mm}^2 \leq S$	: To be zero
	Area	$0.05\text{mm}^2 \leq S < 0.1\text{mm}^2$	: To be max 5points
	Area	$S < 0.05\text{mm}^2$	: None-specify
FILM 刮傷 Film dent (point scratch)	Area	$0.1\text{mm}^2 \leq S$	: To be zero
	Area	$0.05\text{mm}^2 \leq S < 0.1\text{mm}^2$	: To be max 5points
	Area	$S < 0.05\text{mm}^2$	: None-specify
玻璃/FILM 間異物 Foreign material between glass & film	點狀異物 Dot type	Area	$0.1\text{mm}^2 \leq S$ : To be zero
		Area	$0.05\text{mm}^2 \leq S < 0.1\text{mm}^2$ : To be max 5points
		Area	$S < 0.05\text{mm}^2$ : None-specify.
	線狀異物 Line type	Width	$0.1\text{mm} \leq W$
Width		$0.03\text{mm} \leq W < 0.1\text{mm}$ with $L \leq 10\text{mm}$	: To be max 5points
Width		$W < 0.03\text{mm}$	: None-specify
線傷 Line scratch	Width	$0.1\text{mm} \leq W$	: To be zero
	Width	$0.03\text{mm} \leq W < 0.1\text{mm}$ with length $5\text{mm} \leq L \leq 10\text{mm}$	: To be max 5points
		$L < 5\text{mm}$	: None-specify
		$10\text{mm} < L$	: To be zero
	Width	$W < 0.03\text{mm}$	: None-specify
牛頓環 Newton ring	在螢光燈(700Lux 以上)下, 目視(距 Touch Panel 20~30 cm) 判斷 5~10 秒無牛頓環, 但是在同一條件之下從玻璃面所見的牛頓環不在規範內。 Not seen from PANEL film side under fluorescent lamp (700Lux up), exclude from PANEL glass side. (Distance 20~30cm from eyes to Touch Panel)		

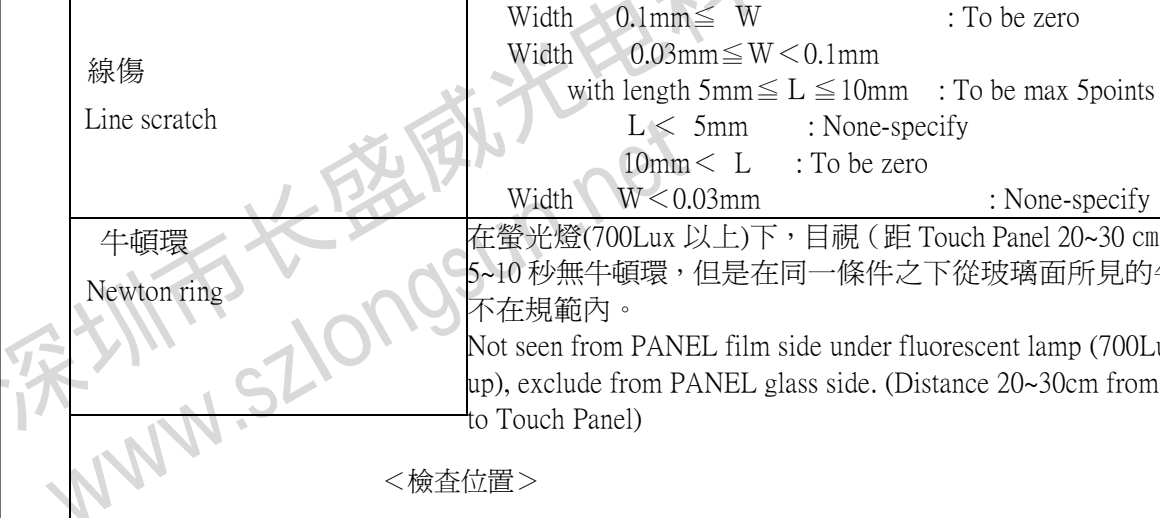

※ S 面積, W 寬、幅, L 長,

DOCUMENT CONTROL SECTION  
DATE

						TITLE: TOUCH PANEL SPEC.	
						DRAW NO. Tech Bes - 04007	
						CUST	
EDIT	DATA	DESIG	CHECK	DESCRIPTION		富晶通科技股份有限公司	
DESIGN	20040427	郭信杰	CHECK	APPR	TRANSTOUCH TECHNOLOGY INC		SHEET 9/12

A

A

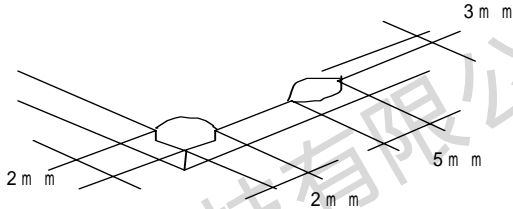
項目 Description	檢查基準 Reject criteria
玻璃瑕疵 Glass flaw	<p>不超過下述的規範值，數量不限。 厚度方向的瑕疵(缺角)最大到板厚為止。 To be no flaw which size is over the drawing Specified as blow. Number of flaw is none-specify. Traveling flaw is none. Flaw of thickness direction size is max.</p> 
Film 外形大小 Film size	<p>FILM 的大小不超出玻璃外形 ( 雙面膠除外 )。 Film is in glass area (or size). (Exclude double-side adhesive tape)</p>
雙面膠大小 Adhesive Tape size	<p>雙面膠的露出不包括在尺寸規定中。 Adhesive Tape out of Panel Outline is excluded.</p>

B

B

C

C

D

D

8. 表示方法 (Showing)

Touch Panel 製造型格及製造年月份表示方法。

Showing to P/No., Production & Year/Month.

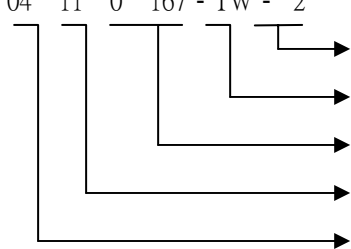
	表示 Showing	意思 Meaning	備考 Notes
製品型格 Product No.	1301-260	T010-1301-T260	Glass 印刷
製造月份 Production Month	<p>Laser mark ( Film side ) (例) 04 11 0 167 - TW - 2</p> 	<p>号機 No. TTI 製造 追番 製造月 製造年(西曆)</p>	<p>追番 1 桁 0 : 量產品 Z : 試作 追番 2~4 桁 1~999 : 当月 Lot 追番</p>

E

E

DOCUMENT CONTROL SECTION  
DATE

				TITLE: TOUCH PANEL SPEC.	
				DRAW NO. Tech Bes - 04007	
				CUST	
EDIT	DATA	DESIG	CHECK	DESCRIPTION	
DESIGN	20040427	郭信杰	CHECK	APPR	
				富晶通科技股份有限公司 TRANSTOUCH TECHNOLOGY INC	
				SHEET 10/12	

F

### 9. 注意事項 Attention

- (1) 本產品是使用玻璃所製，因為玻璃的邊、角是銳利的，在使用觸控面板時請多注意。  
在使用觸控面板時請戴手套作業。  
Since touch panel is consist of Glass, Pls. be careful your hand and other part from injury at handling. You must wear gloves at handling.
- (2) 本產品是使用玻璃所製，在使用觸控面板時，請注意不要施加強力衝擊。  
Do not put a heavy shock or stress on touch panel.
- (3) 拿起觸控面板時請勿從 FPC 拿取。  
Do not lift Touch Panel by cable (FPC).
- (4) 在 FILM 面處請勿施加重力。(例: 在組裝時從 FILM 吸取移動)  
Do not add any stress only film face.  
(Ex. Don't transfer the panel by film face with vacuum)
- (5) 表面清潔時，請使用「乾的柔性布」或「浸泡過中性清潔液擰乾的布」或「沾有酒精的柔性布」。請勿使用有機溶劑、酸、鹼類溶劑。  
Pls. use dry cloth or soft cloth with neutral detergent (after wring dry) or one with ethanol at cleaning. Do not use any organic solvent, acid or alkali solution.
- (6) 保存時請勿重疊放置。特別是請勿用重物壓著。  
Do not pile Touch Panel. Do not put heavy goods on Touch Panel.
- (7) FPC 請勿折彎，有可能使迴路線斷裂。特別是對於連結器的插入部分，因為貼有補強板，在插入連結器時請勿施加過多的力量。請避免以下圖方式插入。  
Do not bend a cable of Touch Panel for prevent happen to line cut failure.  
Please don't use following method for insert the cable to connector.

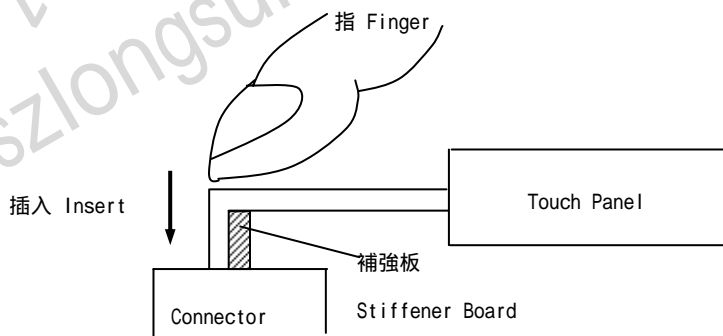

- (8) 在實際組裝設計時，請注意以下事項。  
Please pay attention for the matter as stated below at mounting design of touch panel & enclosure
- 1. 觸控面板的上蓋支撐物請設定在透明範圍的外側。  
(上蓋請勿壓在透明範圍上，會有誤動作的情況發生)  
Enclosure support to fix touch panel must be out of view (transparent) area.  
(Do not design enclosure presses the view area to protect from miss input)

DOCUMENT CONTROL SECTION

DATE

					TITLE: TOUCH PANEL SPEC.	
					DRAW NO. Tech Bes - 04007	
					CUST	
EDIT	DATA	DESIG	CHECK	DESCRIPTION		
DESIGN	20040427	郭信杰	CHECK	APPR	富晶通科技股份有限公司	SHEET 11/12
					TRANSTOUCH TECHNOLOGY INC	

A

-2. 上蓋的外框請設定在透明範圍的內側、動作保證範圍的外側。  
 (上蓋的外框請勿接觸到透明範圍)。  
 Enclosure edge must be between view area & Guaranteed active area.  
 (Enclosure edge must not touch with view area)

B

-3. 觸控面板上下部的壓合，請以橡膠等彈性材質。  
 We recommend the material of support to fix touch panel is elastic material.

-4. 使用時，觸控面板的上面(FILM)請勿與上蓋黏著固定。  
 Do not bond top surface (film) of touch panel with enclosure.

-5. 觸控面板上部的邊角，因為玻璃導電層有傳導性，在組裝設計時請注意不要與金屬材質接觸。  
 The corner parts (fig.\*) has conductivity. Do not touch any metal part after mounting.

-6. 有防水需求時，請考慮用橡膠等材質對迴路週邊做防水。  
 Special design is required for water resistance use.

C

【實裝構造例 Mounting condition example】

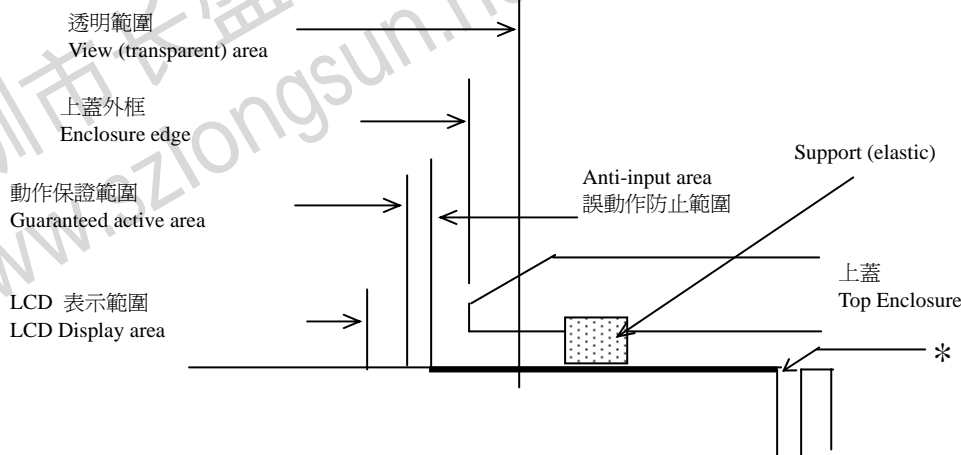

D

DATE	DOCUMENT CONTROL SECTION
------	--------------------------

						TITLE: TOUCH PANEL SPEC.	
						DRAW NO. Tech Bes - 04007	
						CUST	
EDIT	DATA	DESIG	CHECK	DESCRIPTION		富晶通科技股份有限公司	
DESIGN	20040427	郭信杰	CHECK	APPR		TRANSTOUCH TECHNOLOGY INC	SHEET 12/12

F

日期	原圖管理元
----	-------



- Note:
1. Tolerance : ±0.5
  2. Pen&Finger Input Type
  3. Surface Hardness: 3H
  4. Transmissivity: 82 % Typ. (JIS-K7105)
  5. Film: Anti-Glare Type
  6. [03010001-TW-] Lot No. 表示圖例以雷射方式刻印於FILM上

ENGLISH	中文
View Area	透明區域
Active Area	動作保護區域

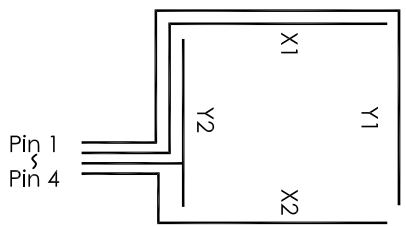
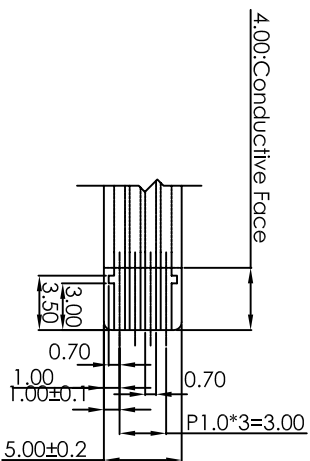
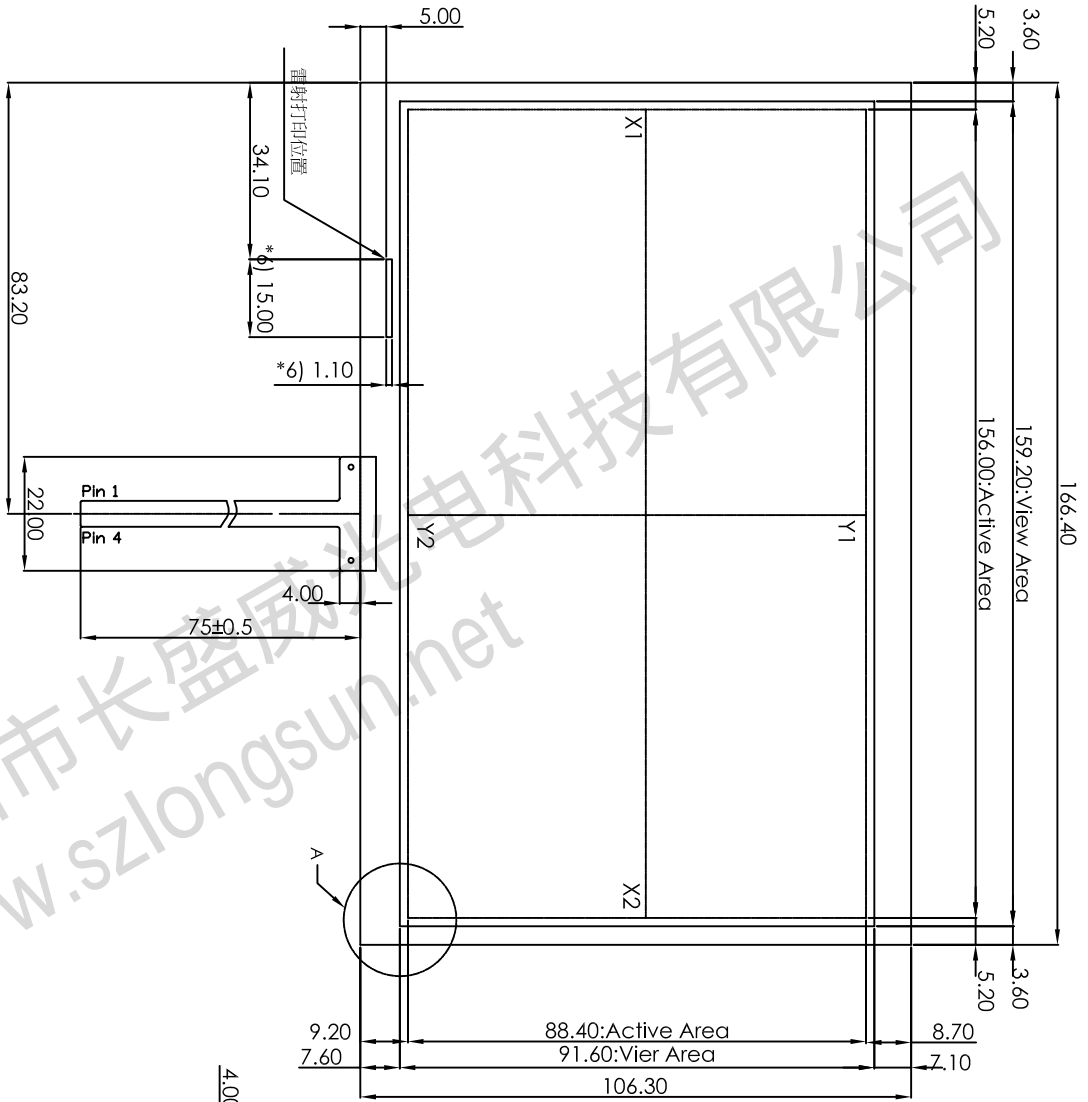

材料	圖號	名稱	比例	提出者
		TOUCH PANEL	1 : 1	
		T010-1301-U260/01		

設計	設計	審查	變更	內容
2004/04/27	AJkuo			承認

日期	設計	設計	審查	變更	內容
2004/04/27	AJkuo				承認

富晶通科技股份有限公司  
95.07 FDN-C-3505-3