

PRODUCT SPECIFICATION

A

A

1. PRODUCT : TOUCH PANEL

2. PART NUMBER :

3. ATTACHED DRAWING : Tech Bes TTI-02025

TOUCH PANEL SPECIFICATION DOCUMENT No.

B

B

SIGNATURE FOR YOUR RECEIPT
-----
DATE:

C

C

TRANSTOUCH TECHNOLOGY INC. (TTI)  
DOCUMENT No. : TTI PRODUCT TECHNOLOGY Dept.

D

D

MANAGER : \_\_\_\_\_ DATE: \_\_\_\_\_  
TTI PRODUCT TECHNOLOGY Dept.  
3F No.50 Hwa-Ya 3<sup>rd</sup> Road ,Kwei-san Shian Tao-yuan ,Taiwan  
TEL(03)3978800 FAX(03)3978855

DOCUMENT CONTROL SECTION  
↑  
DATE

PROPRIETARY NOTE  
This document contains information confidential and proprietary to TRANSTOUCH TECHNOLOGY INC. (TTI) and shall not be reproduced or transferred to other documents or disclosed to other or used for any purpose other than for witch it was obtained without the expressed written consent of TRANSTOUCH TECHNOLOGY INC. (TTI)

E

						TITLE: TOUCH PANEL SPEC.	
						DRAW NO. Tech Bes TTI-02025	
						CUST	
EDIT	DATA	DESIG	CHECK	DESCRIPTION		富晶通科技股份有限公司	
DESIGN	20021218	陳致富	CHECK		APPR	TRANSTOUCH TECHNOLOGY INC	SHEET 1/13

F

1

2

3

4

A

A

B

B

C

C

D

D

E

F

觸控面板製品規格書  
TOUCH PANEL SPECIFICATION

富晶通科技股份有限公司  
TRANSTOUCH TECHNOLOGY INC

www.szlongsun.net  
www.szlongsun.net

DATE	DOCUMENT CONTROL SECTION
------	--------------------------

					TITLE: TOUCH PANEL SPEC.	
					DRAW NO. Tech Bes TTI-02025	CUST
EDIT	DATA	DESIG	CHECK	DESCRIPTION		富晶通科技股份有限公司
DESIGN	20021218	陳致富	CHECK		APPR	TRANSTOUCH TECHNOLOGY INC
						SHEET 2/13

觸控面板製品規格書  
TOUCH PANEL SPECIFICATION

1. 適用範圍 Application

此規格書是適用富晶通科技股份有限公司所製作的觸控面板。

This specification is applied to TOUCH PANEL made by TRANSTOUCH TECHNOLOGY INC. (TTI)。

【製品圖號 手配圖號 Product No.】

品名 Name	製品圖號 P/No.	備註 Remark
觸控面板 TOUCH PANEL	T010-1301-T110	筆/指輸入兼 for pen & finger input

2. 概要 Function

此製品是裝置在 LCD 等平面顯示器上使用電阻薄膜的觸控面板。以先端有小 R 的筆或是以手指按下觸控面板的表面，觸控面板的電壓會透過檢出迴路將座標值檢測出來。

TTI TOUCH PANEL is resistance type that customer uses with flat display like LCD. Once operator touches it by resin PEN with round end or FINGER, the cuircuit for TOUCH PANEL sends coordinate point to PC from voltage at contact point.

3. 製造者 MANUFACTURER

富晶通科技股份有限公司 TRANSTOUCH TECHNOLOGY INC. (TTI)

所在地:桃園縣龜山鄉(華亞科技園區)華亞三路 50 號 3 樓

Address:3F No.50 Hwa-Ya 3<sup>rd</sup> Road ,Kwei-san Shian Tao-yuan ,Taiwan

4. 外型 OUTSIDE

4.1 外型圖 DRAWING

參考最後附加圖面

Please refer the last page of this spec.

DOCUMENT CONTROL SECTION  
DATE

						TITLE: TOUCH PANEL SPEC.	
						DRAW NO. Tech Bes TTI-02025	
						CUST	
EDIT	DATA	DESIG	CHECK	DESCRIPTION		富晶通科技股份有限公司	
DESIGN	20021218	陳致富	CHECK		APPR	TRANSTOUCH TECHNOLOGY INC	
						SHEET 3/13	

4.2 用語定義 Defines of words

用語 Words	定義 Defines
動作保證範圍 Guaranteed active area	觸控面板的特性保證範圍。 Area to be guaranteed all characteristics stated on this spec.
上蓋邊界 Boundary line of top enclosure	表示上蓋外框的建議位置。 Recommended boundary line of top enclosure
透明範圍 View (transparent) area	雙面膠或是從電極內側的透明範圍。 View area which is inside adhesive zone or electrode pattern . Top enclosure must not be fixed by this area.
誤輸入防止範圍 Anti-input area	在透明絕緣的範圍上，防止上蓋邊緣的誤觸動區域 Area to protect miss-input when top enclosure edge touches the touch panel.

5. 特性 Characteristics

5.1 光學特性 Optical characteristics

	項目 ITEM	規格 SPECIFICATION	備註 REMARKS
1	全光線透過率 TRANSPARENCY	80% TYP. (動作保證範圍內) (Inside of guaranteed active area )	JIS K-7105
2	HAZE	5.0% TYP.	

5.2 環境特性 Environmental characteristics

	項目 ITEM	規格 SPECIFICATION	備註 REMARKS
1	動作溫度 Operation temperature	-5°C ~60°C	Max.wetTemp.is38°C (no dew)
2	保存溫度 Storage temperature	-20°C ~70°C	
3	動作濕度 Operation Humid.	20~90% RH	
4	保存濕度 Storage temperature	10~90% RH	

DOCUMENT CONTROL SECTION  
↑  
DATE

					TITLE: TOUCH PANEL SPEC.	
					DRAW NO. Tech Bes TTI-02025	
					CUST	
EDIT	DATA	DESIG	CHECK	DESCRIPTION		富晶通科技股份有限公司 TRANSTOUCH TECHNOLOGY INC
DESIGN	20021218	陳致富	CHECK	APPR		SHEET 4/13

5.3 機械特性 Mechanical characteristics

項目 ITEM	規格 SPECIFICATION	備註 REMARKS
1 表面硬度 Hardness of surface	鉛筆硬度 3H 以上 Pencil hardness 3H min.	JIS K-5400
2 FPC 剝離強度 FPC peeling strength	5N 以上 5N min	向上垂直剝離 Peeling upward by 90°
3 入力荷重 Operation force	筆 Pen	動作保證範圍內 Within" guaranteed active area"
	指 Finger	

5.4 電氣特性 Electrical characteristics

項目 ITEM	規格 SPECIFICATION	備註 REMARKS
1 額定電壓 Rated Voltage	DC 7V max.	
2 電極間電阻 Resistance	X axis : 500Ω ~ 1900Ω (Glass 側)	FPC 連接端測量 At connector
	Y axis : 80Ω ~ 600Ω (Film 側)	
3 直線性 Linearity	MAX : 1.5% 「最初值」 「initial value」 MAX : 3.0% 「環境及壽命試驗後」 「after environmental & life test」	測定條件請參照註 1 Refer Note-1
4 CHATTERING	10ms 以下 max At connector pin	5Hz 測定方式同 6.1 項 Condition: same as 6.1 as stated
5 絕緣電阻 Insulation Resistance	20MΩ 以上(DC 25V)	
	20MΩ min(DC 25V)	

註 1 : Note-1

直線性測定條件

Measurement condition of Linearity

TITLE: TOUCH PANEL SPEC.

DRAW NO. Tech Bes TTI-02025

CUST

EDIT	DATA	DESIG	CHECK	DESCRIPTION
------	------	-------	-------	-------------

富晶通科技股份有限公司	SHEET
TRANSTOUCH TECHNOLOGY INC	5/13

DESIGN	20021218	陳致富	CHECK	APPR
--------	----------	-----	-------	------

DOCUMENT CONTROL SECTION

DATE



在動作保證範圍內，沿著 X、Y 各軸的直線上任意複數點將最外端的點連結成一假想直線，相對於此線的偏差值。直線性是基準電壓分割值得最大偏差電壓。

Difference between actual voltage & theoretical voltage is an error at any points. Linearity is the value max. error voltage divided by voltage difference on active area.

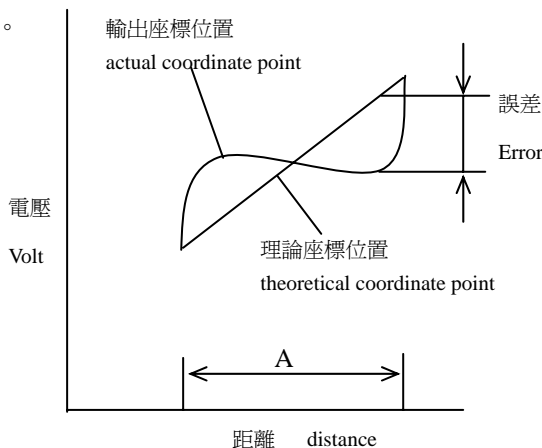

A: 動作保證範圍  
Guaranteed active area

6. 耐久性 life test condition

6.1 機械特性 Mechanical characteristics

1	筆寫壽命 Notes life	10 萬字以上 10 <sup>5</sup> words min	動作保證範圍內 Within "guaranteed active area"
2	打點壽命 Input life	100 萬回以上 10 <sup>6</sup> times min	動作保證範圍內 Within "guaranteed active area"

※ 入力荷重測定條件

Mesurement condition of operation force

按下 film 表面，X 軸 Y 軸間的電阻值在 2kΩ 以下時所測得の入力荷重。

Resistance between X & Y axis must be equal or lower than 2kΩ ( $R_{on} \leq 2k\Omega$ )。

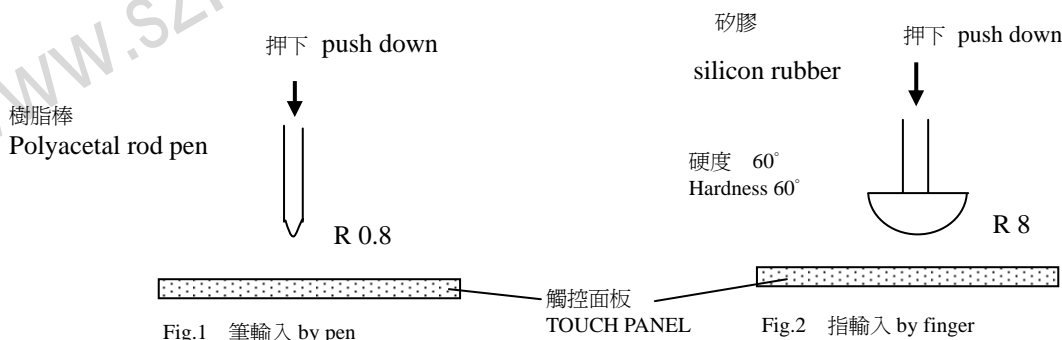

DOCUMENT CONTROL SECTION  
DATE

						TITLE: TOUCH PANEL SPEC.	
						DRAW NO. Tech Bes TTI-02025	
						CUST	
EDIT	DATA	DESIG	CHECK	DESCRIPTION		富晶通科技股份有限公司	
DESIGN	20021218	陳致富	CHECK	APPR	TRANSTOUCH TECHNOLOGY INC		SHEET 6/13

※ 筆寫壽命(耐久性)試驗條件  
Notes life test condition ( by pen )

在動作保證範圍內以任意 A.B.C...7.5 x6.75mm 大小的文字在 10 x9mm 大小區域中，以下記的筆連續書寫。

Notes area for pen notes life test is 10 x 9mm. Size of word is 7.5 x 6.75mm.

Word is any A.B.C..... word. Center of each word is changed at random in notes area.

筆尖端 Shape of pen end : R 0.8 ( Refer Fig.1 )

筆材料 Materials of pen : Polyacetal

入力荷重 Load : 250g

【 判定基準 judge base 】

關於入力荷重、絕緣電阻、電極間電阻需滿足 5.3,5.4 的特性

Operation force, Insulation resistance & Resistance stated before as 5.3 , 5.4 must be within spec.

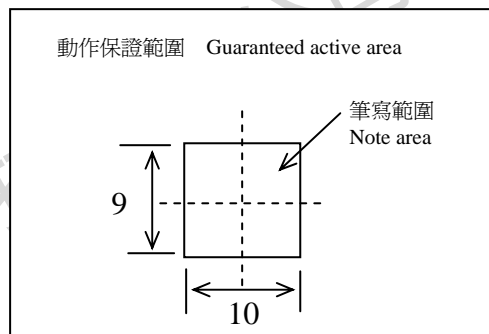

打點壽命(耐久性) 試驗條件 Input life test condition( by finger )

使用矽膠在同一地方連續打點  
By silicon rubber tapping at same point.

橡膠尖端 Sharp of rubber end : R8 硬度 Hardness 60°(Refer fig.2)

操作力 Load : 200g

操作頻率 frequency : 5Hz

【 判定基準 judge base 】

關於入力荷重、絕緣電阻、電極間電阻需滿足 5.3 , 5.4 的特性

Operation force , Insulation resistance & Resistance stated before as 5.3,5.4 must be within spec.

DOCUMENT CONTROL SECTION

DATE

						TITLE: TOUCH PANEL SPEC.	
						DRAW NO. Tech Bes TTI-02025	
						CUST	
EDIT	DATA	DESIG	CHECK	DESCRIPTION		富晶通科技股份有限公司	
DESIGN	20021218	陳致富	CHECK		APPR	TRANSTOUCH TECHNOLOGY INC	SHEET 7/13

### 6.2 環境測試條件 Environmental test condition

項目 ITEM	規格 SPECIFICATION	備註 REMARKS
1 高溫試驗 High temperature	70°C , 240 hr(2hr after test)	關於入力荷重、絕緣電阻、電極間電阻需滿足 5.3 , 5.4 的特性 Operation force, Insulation resistance & Resistance stated before as 5.3, 5.4 must be within spec.
2 低溫試驗 Low temperature	-20°C , 240 hr(2hr after test)	
3 高濕試驗 Humidity	40°C , 95% RH , 240hr (24hr after test)	

### 7. 外觀規格 Appearance.

#### 7.1 外觀基準適用領域(範圍) Scope of reject criteria.

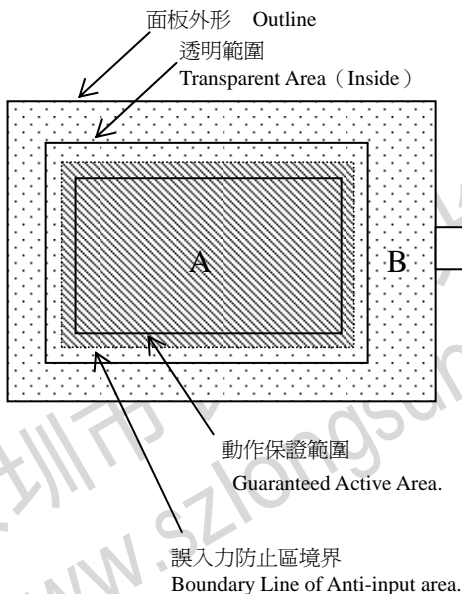

領域 Area	外觀仕様 Spec.
A	使用上不會有可視的缺失而影響正常操作。檢查基準依據 7-2 項。 Without any defect point to effect on normal operation.
B	不檢查 None-specify.

A : 誤入力防止區境界(波浪狀)的內側區域  
Inside of Boundary Line of Anti-input area. (wavy-pattern)

B : 領域 A 以外

Without A area. Input area refers to drawing as left.

#### 7.2 檢查基準 Reject criteria.

項目 Description	檢查基準 Reject criteria
FILM 打痕(魚眼) Film fish eye	Area 0.1mm <sup>2</sup> S : To be zero
	Area 0.05mm <sup>2</sup> S < 0.1mm <sup>2</sup> : To be max 5points
	Area S < 0.05mm <sup>2</sup> : None-specify

TITLE: TOUCH PANEL SPEC.

DRAW NO. Tech Bes TTI-02025

CUST

EDIT DATA DESIG CHECK DESCRIPTION

DESIGN 20021218 陳致富 CHECK APPR

富晶通科技股份有限公司  
TRANSTOUCH TECHNOLOGY INC

SHEET

8/13

DOCUMENT CONTROL SECTION

DATE



A

A

FILM 刮傷 Film dent	Area	0.1mm <sup>2</sup>	S	: To be zero
	Area	0.05mm <sup>2</sup>	S < 0.1mm <sup>2</sup>	: To be max 5points
	Area	S < 0.05mm <sup>2</sup>		: None-specify

B

B

玻璃/FILM 間異物 Foreign material between glass & film	點狀異物 Dot type	Area	0.1mm <sup>2</sup>	S	: To be zero
		Area	0.05mm <sup>2</sup>	S < 0.1mm <sup>2</sup>	: To be max 5points
		Area	S < 0.05mm <sup>2</sup>		: None-specify.
	線狀異物 Line type	Width	0.1mm	W	: To be zero
		Width	0.03mm	W < 0.1mm with length L < 10mm	: To be max 5points
		Width	W < 0.03mm		: None-specify

C

C

線傷 Scratch	Width	0.1mm	W	: To be zero
	Width	0.03mm	W < 0.1mm with length L < 40mm	: To be max 1points
	Width	0.03mm	W < 0.1mm with length 5mm L 10mm	: To be max 5points
	Width	W < 0.03mm		: None-specify

牛頓環  
Newton ring

在螢光燈(700Lux 以上)下，目視(距 Touch Panel 20~30 cm)判斷 5~10 秒無牛頓環，但是在同一條件之下從玻璃面所見的牛頓環不在規範內。  
Not seen from PANEL film side under fluorescent lamp (700Lux up), exclude from PANEL glass side. (Distance 20~30cm from eyes to Touch Panel)

D

D

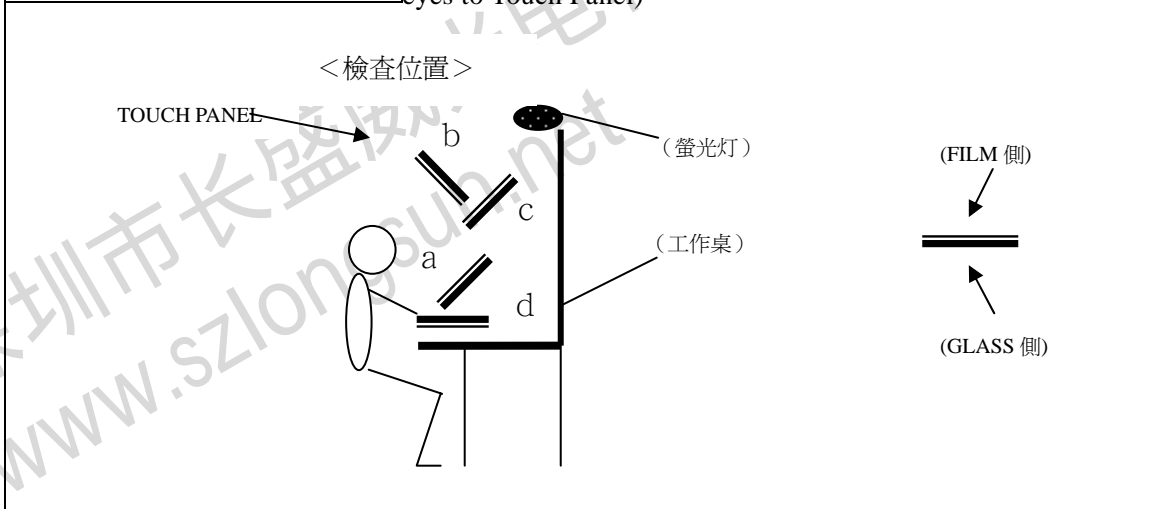

S 面積, W 寬、幅, L 長,

DOCUMENT CONTROL SECTION

DATE

						TITLE: TOUCH PANEL SPEC.	
						DRAW NO. Tech Bes TTI-02025	
						CUST	
EDIT	DATA	DESIG	CHECK	DESCRIPTION		富晶通科技股份有限公司	
DESIGN	20021218	陳致富	CHECK	APPR	TRANSTOUCH TECHNOLOGY INC		SHEET 9/13

A

A

項目 Description	檢查基準 Reject criteria
玻璃瑕疵 Glass flaw	不超過下述的規範值，數量不限。 厚度方向的瑕疵(缺角)最大到板厚為止。 To be no flaw which size is over the drawing Specified as blow. Number of flaw is none-specify. Traveling flaw is none. Flaw of thickness direction size is max. <div data-bbox="730 734 1248 981" style="text-align: center;"> </div>
Film 外形大小 Film size	FILM 的大小不超出玻璃外形 ( 雙面膠除外 )。 Film is in glass area (or size). (Exclude double-side adhesive tape)
雙面膠大小 Adhesive Tape size	雙面膠的露出不包括在尺寸規定中。 Adhesive Tape out of Panel Outline is excluded.

B

B

C

C

D

D

DOCUMENT CONTROL SECTION	↑
DATE	

E

					TITLE: TOUCH PANEL SPEC.	
					DRAW NO. Tech Bes TTI-02025	
					CUST	
EDIT	DATA	DESIG	CHECK	DESCRIPTION		
DESIGN	20021218	陳致富	CHECK		APPR	
					富晶通科技股份有限公司 TRANSTOUCH TECHNOLOGY INC	
					SHEET	10/13

F

### 8. 表示方法(showing)

Touch Panel 製造型格及製造年月份表示方法。

Showing to P/No., Production & Year/Month.

	表示 Showing	意思 Meaning	備考 Notes
製品型格 Product No.	1301-110	T010-1301-T110	
製造年 Production Year	2 3 4 3 4	2002 年製造 2002 Production 2003 年製造 2003 Production	可視的第一個數字表示製造西元年最後一數字。 First number show to Production Year.
製造月份 Production Month		3 月製造 March Production 6 月製造 June Production	點(·)表示製造月份(●表示 5 月及 10 月) Point(·)show to Month (●is May, Oct) 刪除的下個點表示製造月 Next to erase point show to Production Month.

### 9. 注意事項 Attention

(1) 本產品是使用玻璃所製，因為玻璃的邊、角是銳利的，在使用觸控面板時請多注意。  
在使用觸控面版時請戴手套作業。

Since touch panel is consist of Glass, pls. be careful your hand and other part from injury at handling. You must wear gloves at handling.

(2) 本產品是使用玻璃所製，在使用觸控面板時，請注意不要施加強力衝擊。  
Do not put a heavy shock or stress on touch panel.

(3) 拿起觸控面板時請勿從 FPC 拿取。  
Do not lift Touch Panel by cable (FPC).

(4) 在 FILM 面處請勿施加重力。(例: 在組裝時從 FILM 吸取移動)  
Do not add any stress only film face.  
(Ex. Don't transfer the panel by film face with vacuum)

(5) 表面清潔時，請使用「乾的柔性布」或「浸泡過中性清潔液擰乾的布」或「沾有酒精的柔性布」。請勿使用有機溶劑、酸、鹼類溶劑。  
Pls. use dry cloth or soft cloth with neutral detergent (after wring dry) or one with ethanol at cleaning. Do not use any organic solvent, acid or alkali solution.

DOCUMENT CONTROL SECTION

DATE

						TITLE: TOUCH PANEL SPEC.	
						DRAW NO. Tech Bes TTI-02025	
						CUST	
EDIT	DATA	DESIG	CHECK	DESCRIPTION		富晶通科技股份有限公司	
DESIGN	20021218	陳致富	CHECK	APPR	TRANSTOUCH TECHNOLOGY INC		SHEET 11/13

(6) 保存時請勿重疊放置。特別是請勿用重物壓著。

Do not pile Touch Panel. Do not put heavy goods on Touch Panel.

(7) FPC 請勿折彎，有可能使迴路線斷裂。特別是對於連結器的插入部分，因為貼有補強板，在插入連結器時請勿施加過多的力量。請避免以下圖方式插入。

Do not bend a cable of Touch Panel for prevent happen to line cut failure.

Please don't use following method for insert the cable to connector.

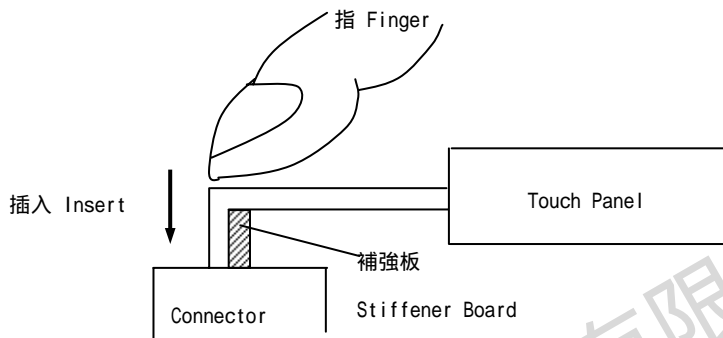

(8) 在實際組裝設計時，請注意以下事項。

Please pay attention for the matter as stated below at mounting design of touch panel & enclosure

- 1. 觸控面板的上蓋支撐物請設定在透明範圍的外側。  
(上蓋請勿壓在透明範圍上，會有誤動作的情況發生)

Enclosure support to fix touch panel must be out of view (transparent) area.

(Do not design enclosure presses the view area to protect from miss input)

- 2. 上蓋的外框請設定在透明範圍的內側、動作保證範圍的外側。  
(上蓋的外框請勿接觸到透明範圍)。

Enclosure edge must be between view area & Guaranteed active area.

(Enclosure edge must not touch with view area)

- 3. 觸控面板上下部的壓合，請以橡膠等彈性材質。

We recommend the material of support to fix touch panel is elastic material.

- 4. 使用時，觸控面板的上面(FILM)請勿與上蓋黏著固定。

Do not bond top surface (film) of touch panel with enclosure.

DOCUMENT CONTROL SECTION  
DATE

						TITLE: TOUCH PANEL SPEC.	
						DRAW NO. Tech Bes TTI-02025	
						CUST	
EDIT	DATA	DESIG	CHECK	DESCRIPTION		富晶通科技股份有限公司	
DESIGN	20021218	陳致富	CHECK		APPR	TRANSTOUCH TECHNOLOGY INC	SHEET 12/13

-5. 觸控面板上部的邊角，因為玻璃導電層有傳導性，在組裝設計時請注意不要與金屬材質接觸。  
The corner parts (fig.\*) has conductivity. Do not touch any metal part after mounting.

-6. 有防水需求時，請考慮用橡膠等材質對迴路週邊做防水。  
Special design is required for water resistance use.

【實裝構造例 Mounting condition example】

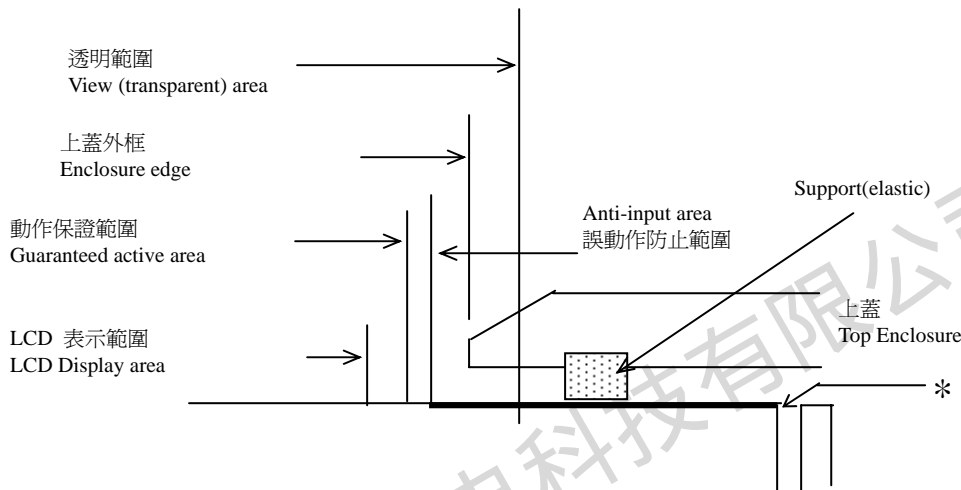

DATE	↑ DOCUMENT CONTROL SECTION

						TITLE: TOUCH PANEL SPEC.	
						DRAW NO. Tech Bes TTI-02025	
						CUST	
EDIT	DATA	DESIG	CHECK	DESCRIPTION		富晶通科技股份有限公司	
DESIGN	20021218	陳致富	CHECK		APPR		
						SHEET 13/13	

DATE	DOCUMENT CONTROL SECTION
------	--------------------------

1 2 3 4 5 6 7 8

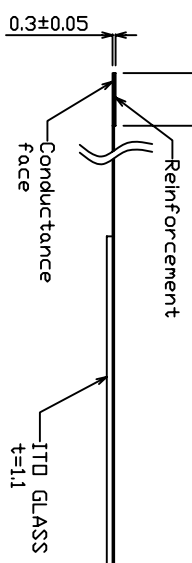
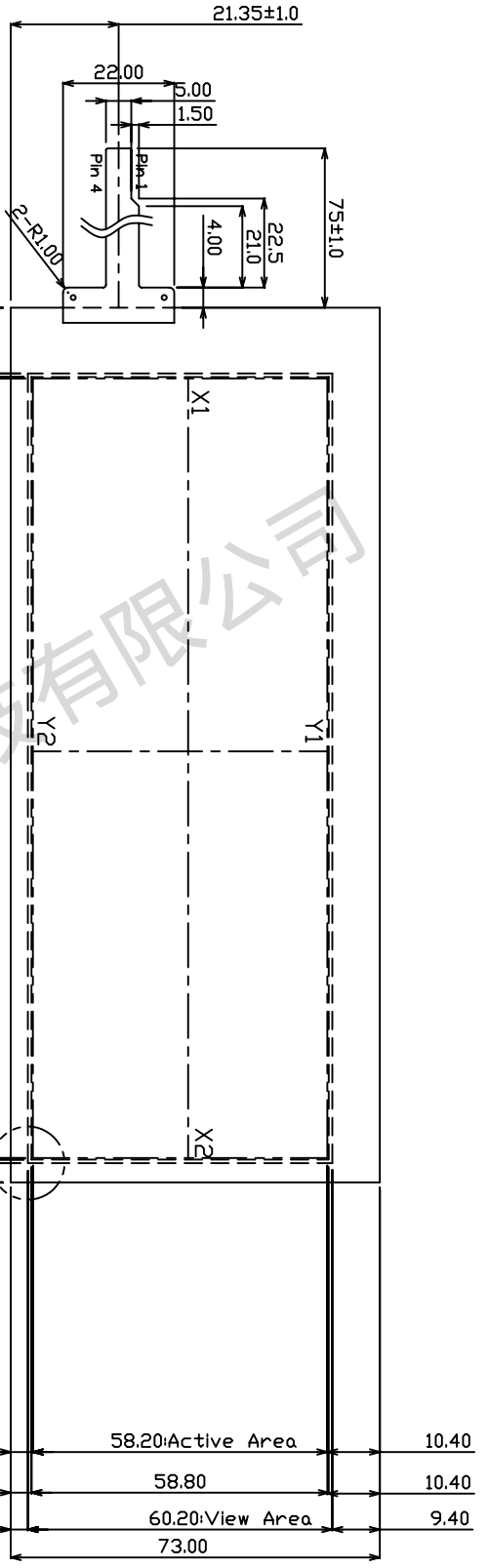

Pin No.	SYMBOL
1	X2
2	Y1
3	X1
4	Y2

NOTE  
 1.Tolerance No Specified±0.5  
 2.Anti-Glare TYPE  
 3.Protective film on film side.  
 4.Pen and Finger type.

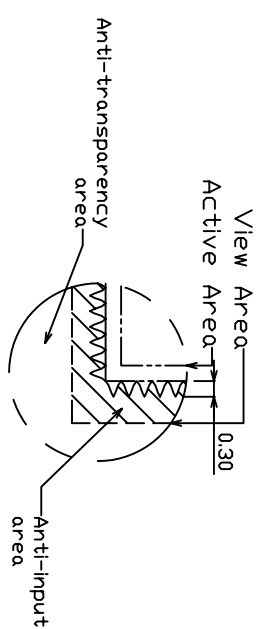
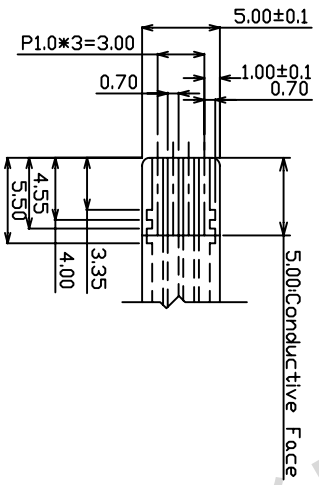

DETAIL A

Item	Dimension	Commercial Tolerance	Class
Center distance (metal)	±0.1	Q5-120	Class C
Center distance (resin)	±0.15	315	Class C
General dimensions (metal)	±0.2	1000	Class C
General dimensions (resin)	±0.25	POD	Class C
Assembly dimensions	±0.3	±0.3	Class C
Individual (by 315 or less)	±0.4	±0.4	Class C
	±0.5	±0.5	Class C
	±0.8	±0.8	Class C
	±1.2	±1.2	Class C

DATE	DESIG.	CHECK	DESCRIPTION	TITLE
20021212	陳啟豪			TOUCH PANEL OUTSIDE
				SCALE :
				DRAW. NO. T010-1301-U110
				CUST.
				TRANSTOUCH TECHNOLOGY INC.
				97.01 FDNCA30051