

SPECIFICATION

USB/232 COMBO CONTROL CHIP FOR 4-/5-WIRE TOUCHSCREEN

ITEM NO. : ET1407

VERSION : 2.1

DATE : 2011/06

CONTENT

1. GENERAL DESCRIPTION	2
2. FEATURES	2
3. BLOCK DIAGRAM	2
4. PIN ASSIGNMENT	3
5. FUNCTION SPECIFICATIONS.....	4
5.1 POWER ON RESET.....	4
5.2 TOUCH-PANEL FUNCTION	4
5.3 ELECTRICAL CHARACTERISTICS.....	6
6. EXTERNAL DIAGRAM.....	7

NOTE

ET&T reserves the right to change product or specifications without notice.

All trademark is belonged to all origin company.

1. GENERAL DESCRIPTION

The control IC is designed for fully integrated 4 or 5 wire resistive touchscreen application and supports USB or RS232 interface. It provides 12 bit ADC resolution. It is good for pen-touch with low-power application. It can apply to most of the resistive touchscreen panel.

2. FEATURES

- Support USB 1.1 or RS232 interface.
- High resolution, excellent accuracy. (4096 x 4096 12 bit ADC)
- Wide operation voltage, Low power consumption.
- Single chip design. (low power and space saving)
- Wide operation temperature, durable and reliable. (-40 ~ 85 °C)
- Cost effective, less component required to build up circuit.
- Supports multiple operating systems. (Windows, Linux, Mac OS)
- Package : LQFP 48pin. (9.0 x 9.0 x 1.4mm)

3. BLOCK DIAGRAM

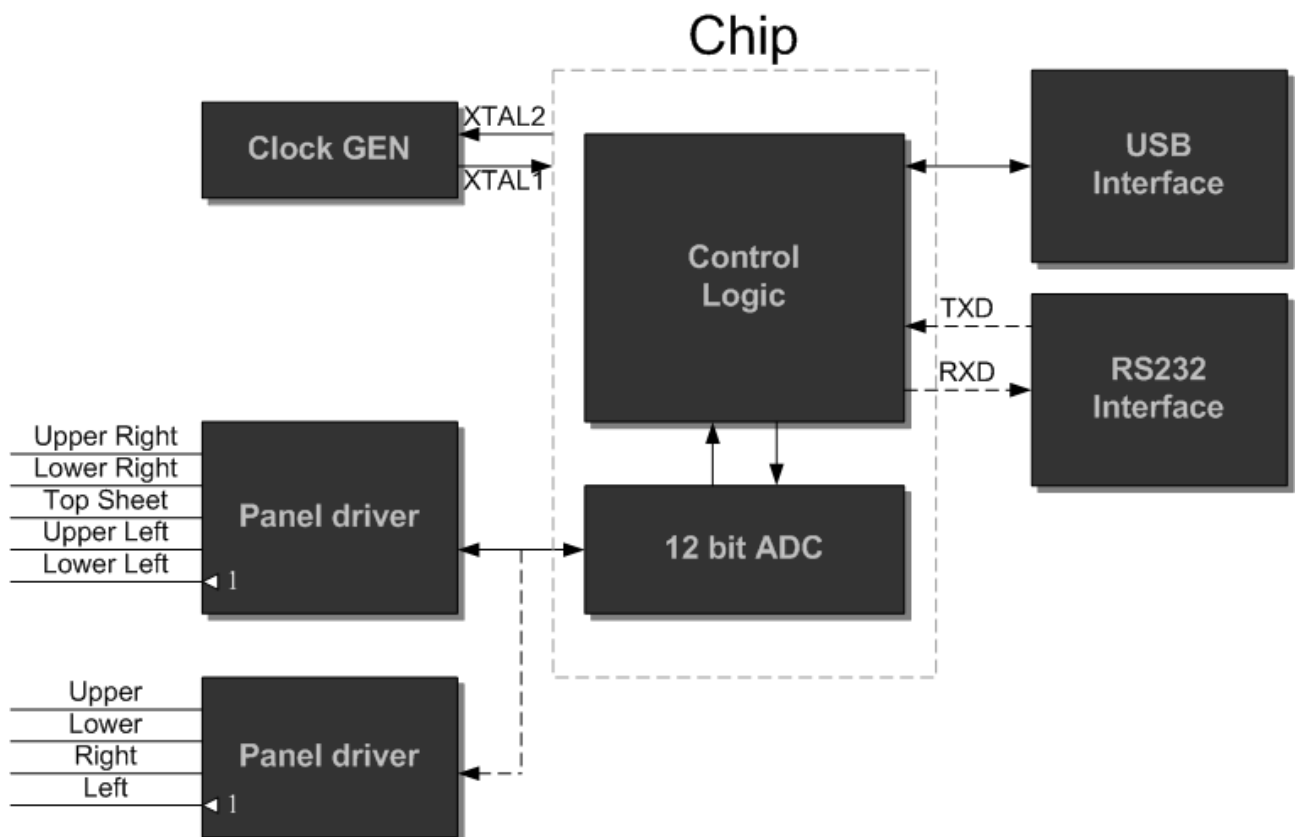

4. PIN ASSIGNMENT

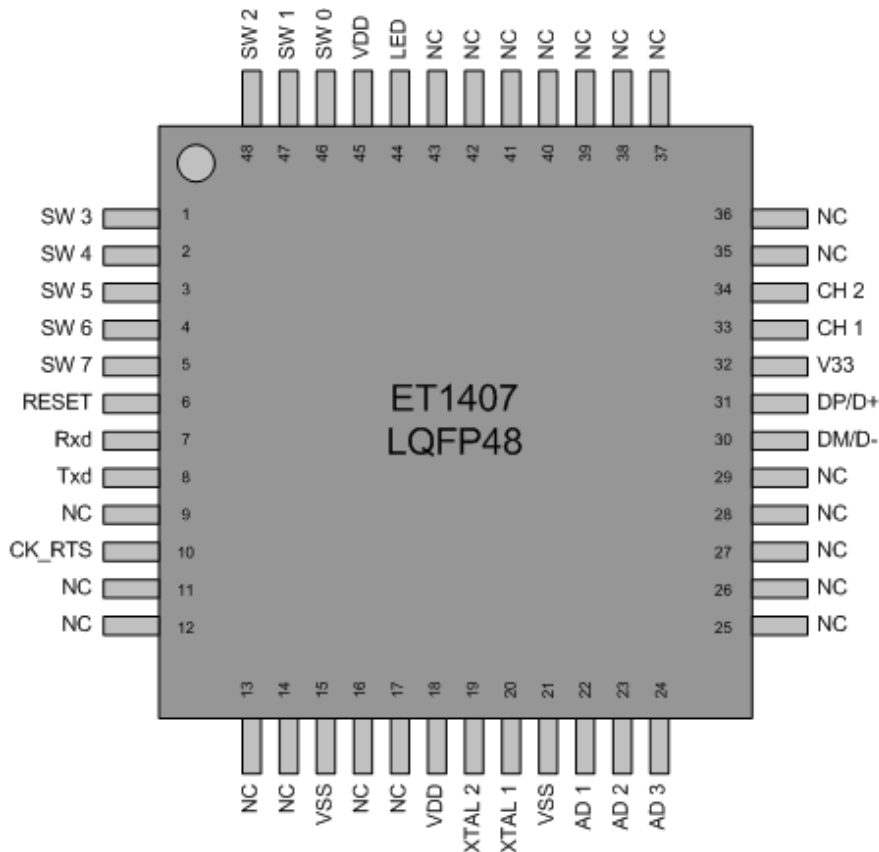

Pin No.	Name	Description	Pin No.	Name	Description
1	SW 3	Chip I/O switch pin	25	NC	-
2	SW 4	Chip I/O switch pin	26	NC	-
3	SW 5	Chip I/O switch pin	27	NC	-
4	SW 6	Chip I/O switch pin	28	NC	-
5	SW 7	Chip I/O switch pin	29	NC	-
6	RESET	Chip reset pin	30	DM/D-	USB D- signal
7	Rxd	Serial bus receive port	31	DP/D+	USB D+ signal
8	Txd	Serial bus transmit port	32	V33	3.3V regulation output
9	NC	-	33	CH 1	Choose Chip mode
10	CK_RTS	Check RTS signal	34	CH 2	Choose Chip mode
11	NC	-	35	NC	-
12	NC	-	36	NC	-
13	NC	-	37	NC	-
14	NC	-	38	NC	-
15	VSS	Power ground	39	NC	-
16	NC	-	40	NC	-
17	NC	-	41	NC	-
18	VDD	+5V power supply	42	NC	-
19	XTAL 2	Crystal output *	43	NC	-
20	XTAL 1	Crystal input *	44	LED	LED signal
21	VSS	Power ground	45	VDD	+5V power supply
22	AD 1	Chip A/D input	46	SW 0	Chip I/O switch pin
23	AD 2	Chip A/D input	47	SW 1	Chip I/O switch pin
24	AD 3	Chip A/D input	48	SW 2	Chip I/O switch pin

* The clock frequencies depends on the circuit diagram.

5. FUNCTION SPECIFICATIONS

5.1 POWER ON RESET

MCU is high level reset for at least 80ms while the Oscillator is running in order to reset the entire MCU.

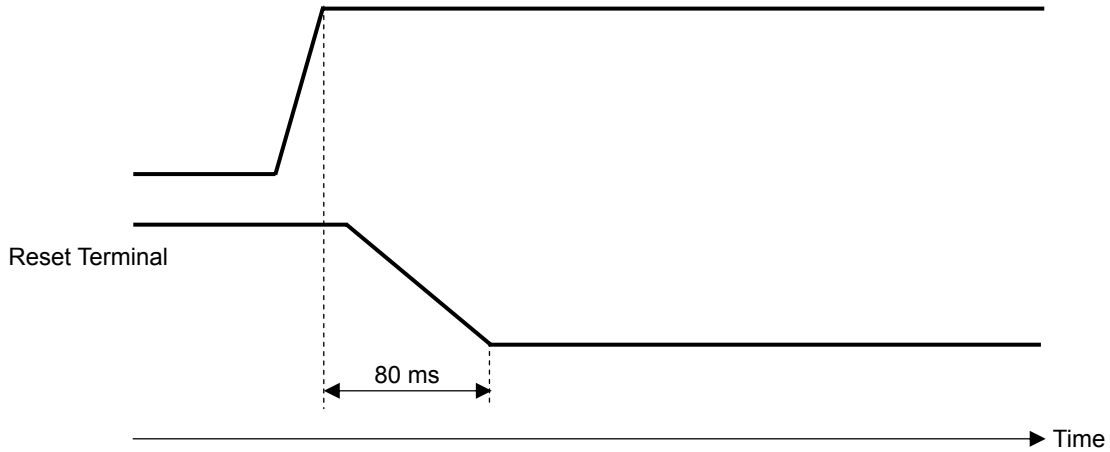

5.2 TOUCH-PANEL FUNCTION

5.2.1 Coordinate Placement

This board outputs is assumed to be X-Y rectangular coordinate placement. The coordinate placement shows that the corner of the panel is a starting point and the diagonal corner becomes the maximum. Both X and Y maximum values are 12bit=FFFH=4095d.

5.2.2 USB Output Data

MCU on this board notifies the host side data by the HID report descriptor of the Mouse collection in accordance with HID spec 1.1.

MCU on this board generates 12bit coordinates by using built-in ADC.

The output data format is as following

Byte	Definition	Explanation
Byte 0	Touch ON/OFF	Touch ON/OFF Fixation
Byte 2 ~ Byte 1	X Coordinates	The Data Numerical Value is 0~4095(Max)
Byte 4 ~ Byte 3	Y Coordinates	The Data Numerical Value is 0~4095(Max)

5.2.3 RS232 Output Data

Byte	Definition	Explanation (Bit format)							
		Bit7	Bit6	Bit5	Bit4	Bit3	Bit2	Bit1	Bit0
Byte0	Header	1	Flag Bit6	0	0	Flag Bit3	Flag Bit2	Flag Bit1	Flag Bit0
Byte1	X position	0	X pos	X pos	X pos	X pos	X pos	X pos	X pos
	High Byte		Bit13	Bit12	Bit11	Bit10	Bit09	Bit08	Bit07
Byte2	X position	0	X pos	X pos	X pos	X pos	X pos	X pos	X pos
	Low Byte		Bit06	Bit05	Bit04	Bit03	Bit02	Bit01	Bit00
Byte3	Y position	0	Y pos	Y pos	Y pos	Y pos	Y pos	Y pos	Y pos
	High Byte		Bit13	Bit12	Bit11	Bit10	Bit09	Bit08	Bit07
Byte4	Y position	0	Y pos	Y pos	Y pos	Y pos	Y pos	Y pos	Y pos
	Low Byte		Bit06	Bit05	Bit04	Bit03	Bit02	Bit01	Bit00

Flag Bit6: 0 Untouch
 1 Touch

5.2.3 Plug and play(PnP) ID response

Transfer rate : 1200bps.
 Data transmission mode : Asynchronous start-stop synchronization.
 Signal level : Conforming to RS-232-C

The operation when PnP ID is transmitted to the host is described as follows.

RTS means host's RTS signal, and H means +12V (space),L means -12V(mark).

The set 4 wire function responds that the response of PnP ID : Synchronizing with standing up of RTS=H(DTR signal is H) after 100ms. The following 22 bytes respond. 28H, 01H, 24H, 54H, 54H, 54H, 30H, 30H, 30H, 32H, 5CH, 5CH, 5CH, 5CH, 34H, 57H, 32H, 33H, 32H, 46H, 34H, 29H.(hexadecimal mark)

The set 5 wire function responds that the response of PnP ID : Synchronizing with standing up of RTS=H(DTR signal is H) after 100ms. The following 22 bytes respond. 28H, 01H, 24H, 54H, 54H, 54H, 30H, 30H, 30H, 32H, 5CH, 5CH, 5CH, 5CH, 35H, 57H, 32H, 33H, 32H, 46H, 34H, 29H.(hexadecimal mark)

When Power on is reset (DTR signal is H), this MCU is executed the PnP ID response. Connect DTR with RTS in the loop back on the PC side when you use the PnP function on windows PC.

5.3 ELECTRICAL CHARACTERISTICS

5.3.1 Absolute Maximum Rating

Item	Description
DC Supply Voltage	-0.3 to 7.0
Input / Output Voltage	GND -0.3 to VCC +0.3
Operating Ambient Temperature (°C)	-40 to 85
Storage Temperature (°C)	-50 to 125
Operating Voltage (VCC)	+3.3 to 5.5

5.3.2 DC Electrical Characteristics

(VCC=5V±5%, GND=0V, TA=0~70°C, Fosc=6MHz, Unless Otherwise Noted)

Symbol	Parameter	Condition	Min	Type	Max	Units
VDD	Supply Voltage		3.0	—	5.5	V
V _{IH}	Input High Voltage		0.7V _{DD}	—	V _{DD} +0.3	V
V _{IL}	Input Low Voltage		-0.3	—	0.3V _{DD}	V
V _{OH}	Output High Voltage (AD1~3)	I _{OH} = -25mA	V _{DD} -2.0	—	V _{DD}	V
V _{OH}	Output High Voltage (SW0~7)	I _{OH} = -80μA	2.4	—	—	V
V _{OL}	Output Low Voltage (AD1~3)	I _{OL} = 25mA	0		0.4	V
V _{OL}	Output Low Voltage (SW0~7)	I _{OL} = 1.6mA	—		0.45	V
I _{IL}	Input Leakage Current	0V < V _{IN} < V _{DD}	-2	—	2	μA
R _{PH}	Pull High Resistance			25		Kohm
I _{DD,OPT}	Operating Mode Current	Fosc=6MHz, No load		11		mA
I _{DD,IDL}	Idle Mode Current	Fosc=6MHz, No load V3.3 regulator and 1.5K register turn off			200	μA
I _{DD,PD}	Power Down Mode Current	Oscillator disabled, No load, V3.3 regulator and 1.5K register turn off			15	μA
V33	3.3 Regulator Output		3.0	3.3	3.6	V
V _{RESET}	Reset Voltage		3.5	3.6	3.7	V

6. EXTERNAL DIAGRAM

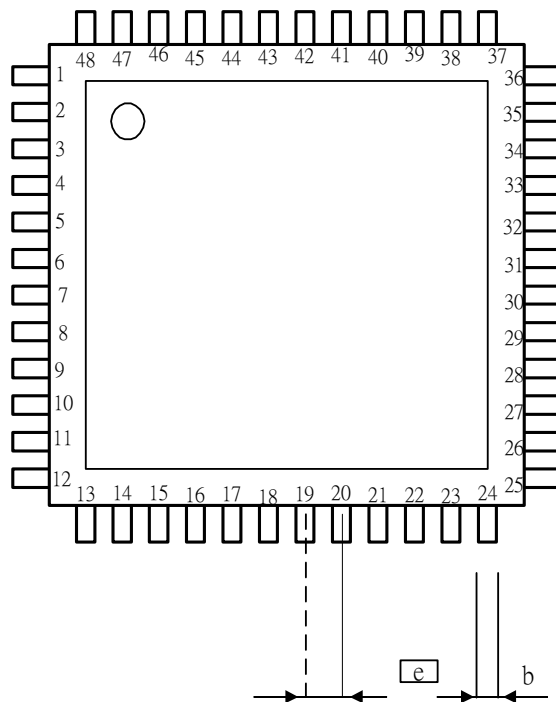

SYMBOL	DIMENSION(MM)			DIMENSION(MIL)		
	MIN	NON	MAX	MIN	NON	MAX
A			1.60			63
A1	0.05		0.15	2		6
A2	1.35	1.40	1.45	53	55	57
b	0.17	0.22	0.27	7	9	11
b1	0.17	0.20	0.23	7	8	12
c	0.09		0.20	4		8
c1	0.09		0.16	4		6
D		9.00 BSC			354 BSC	
D1		7.00 BSC			276 BSC	
E		9.00 BSC			354 BSC	
E1		7.00 BSC			276 BSC	
e		0.50 BSC			20 BSC	
L	0.45	0.60	0.75	18	24	30
L1		1.00 REF			39 REF	
R1	0.08			3		8
R2	0.08		0.20	3		3
Y			0.075			7°
⊖	0°	3.5°	7°	0°	3.5°	
⊖1	0°			0°		
⊖2	11°	12°	13°	11°	12°	13°
⊖3	11°	12°	13°	11°	12°	13°

